

Boreal

Notice d'installation



Modèle Boreal Sigma

1820x1220x2150mm - Tension :AC220-240V

- Sauna infrarouge :1650W - 16A - 220V
- Générateur de vapeur :3000W - 16A - 220V









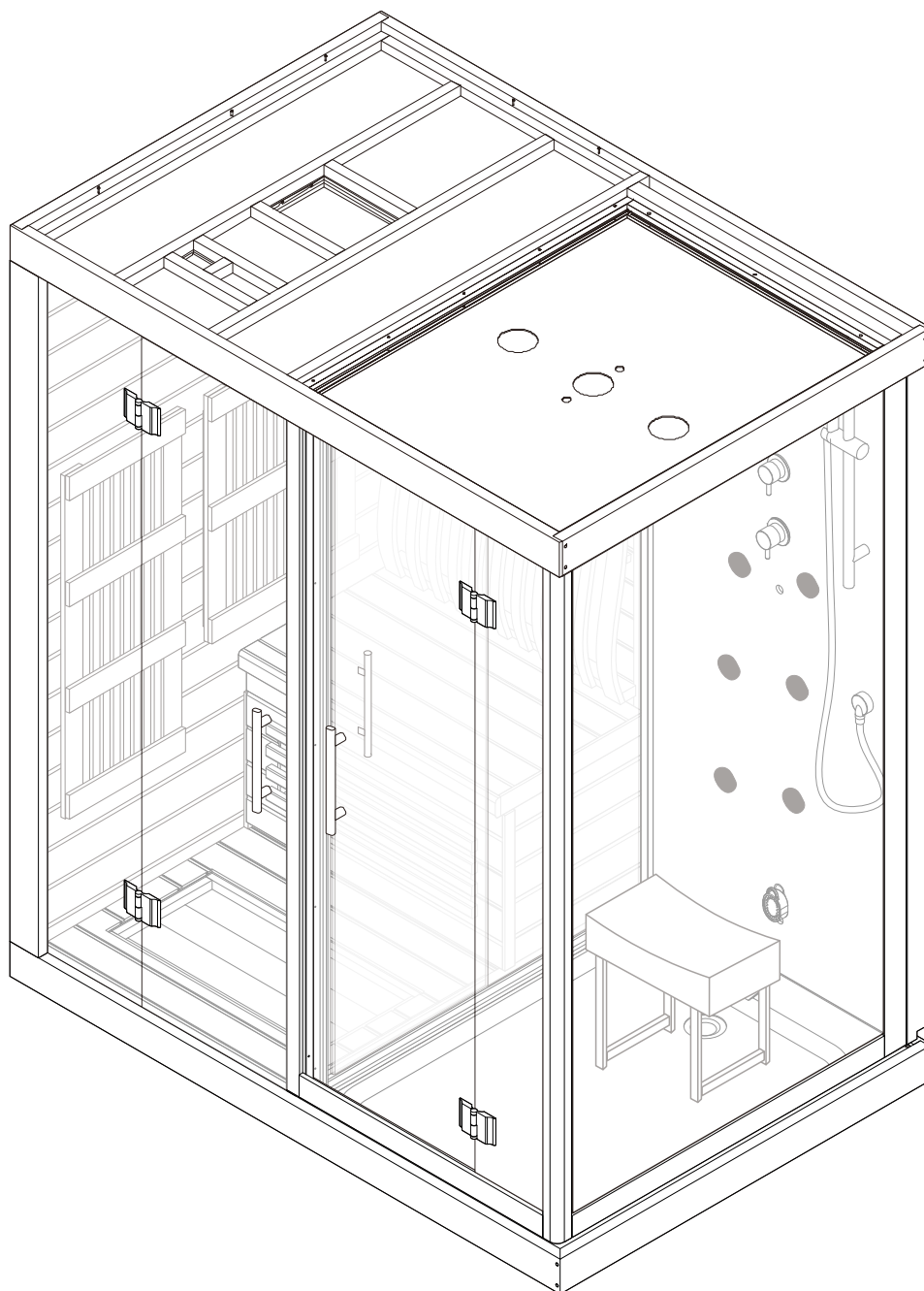

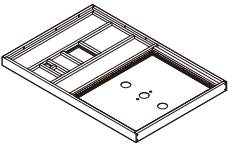
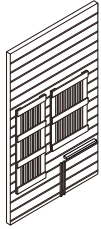
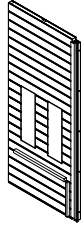

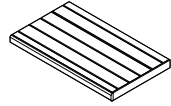

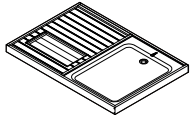

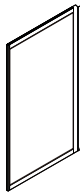

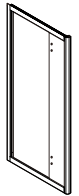



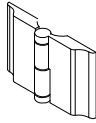

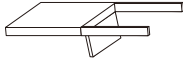
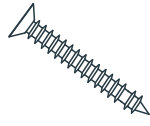
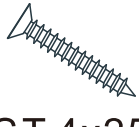

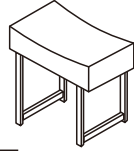
Arrivées électriques - prévoir au choix:

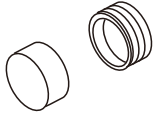
- Soit 2 lignes de 16A - 220V - 3x2.5mm²
- Soit 1 ligne de 25A - 220V - 3 x 4mm²

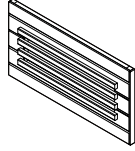
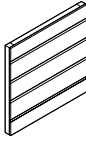
Fréquence nominale: 50/60HZ

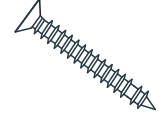
Résistance isolée :>20M Ω



						01	X102	X103	X104	X105	X106	X1	
						07	X108	X109	X110	X111	X112	X1	
						13	X114	X115	X316	X417	X218	X10	
						19	X220	X821	X722	X423	X124	X8	
						25	X726	X927	X128	X129	X230	X6	
 small head screw ST 4x12	 big head screw ST 4x12	 M4x25	 M4			31	X12	32	X20	33	X2	34	X2

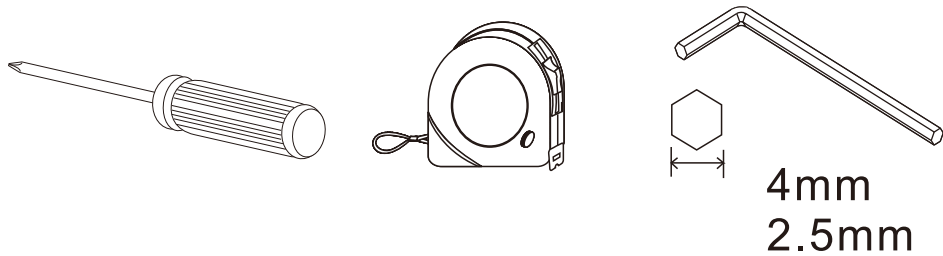

Etape:01

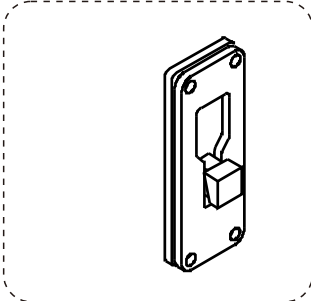
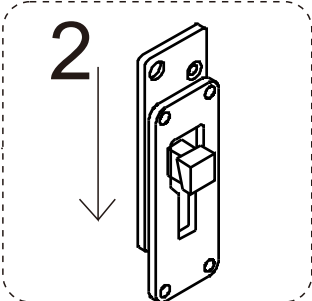
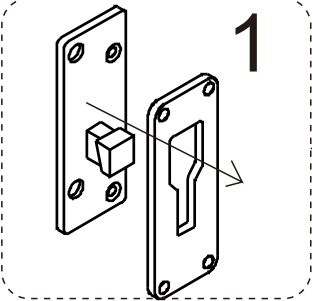
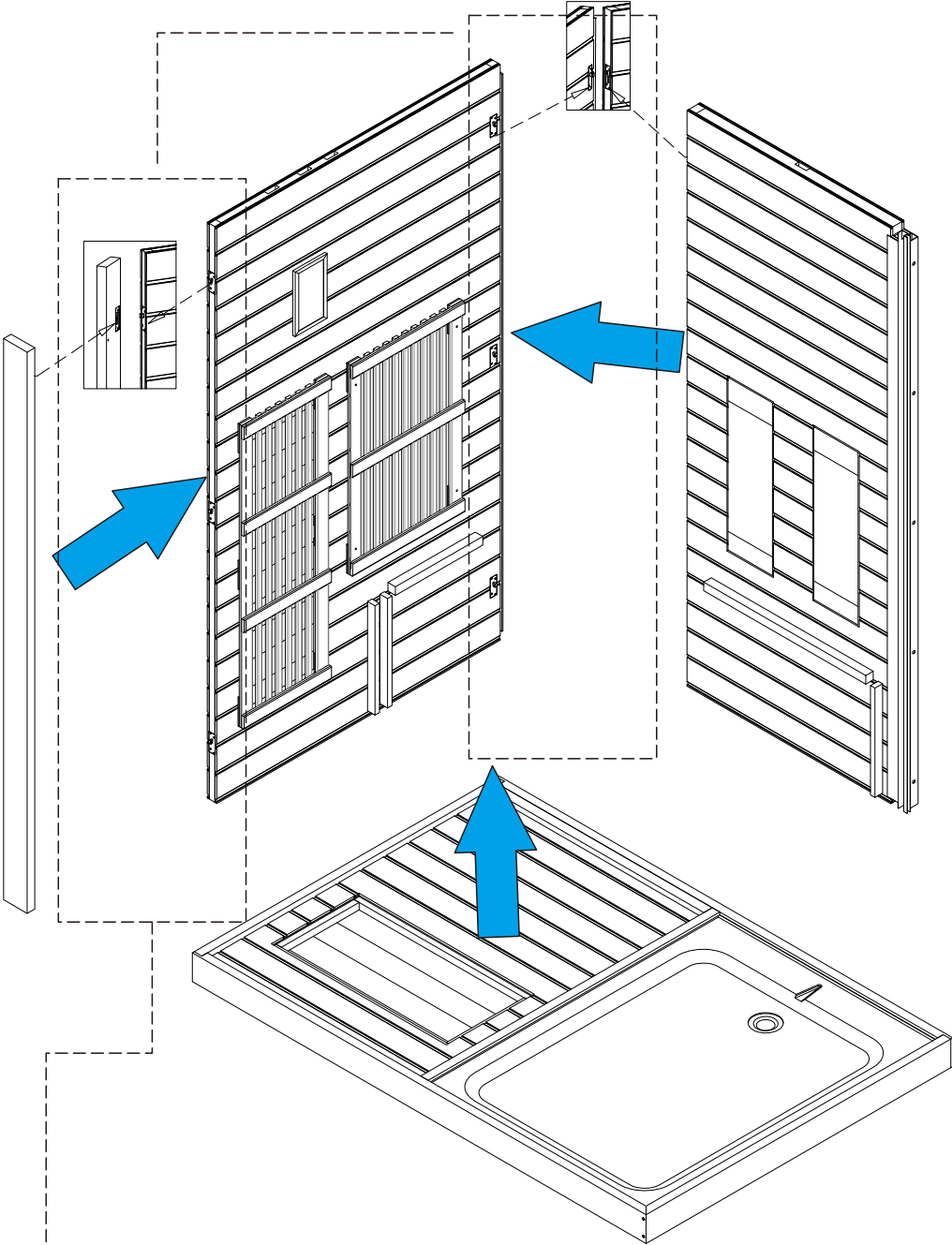
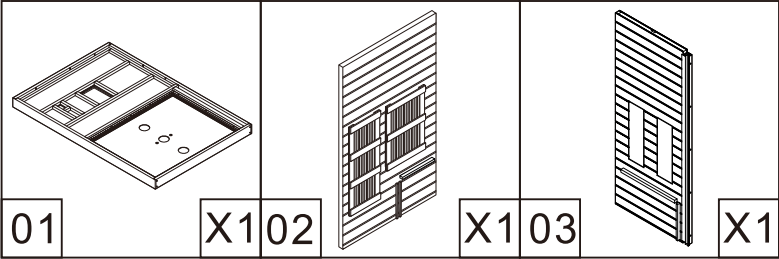

Etape:02

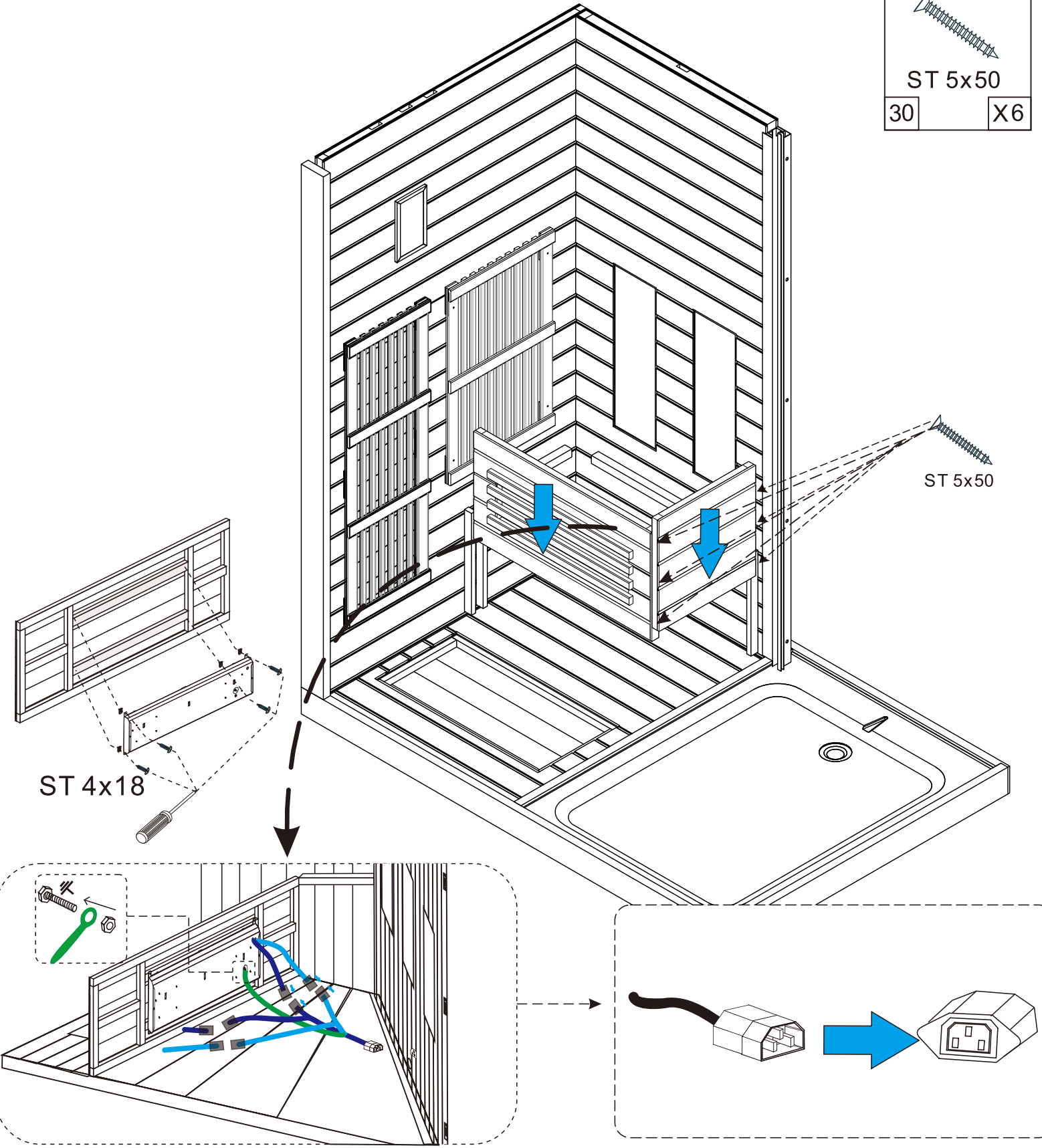

27	X128	X1	X1	X4
				ST 4x18
				ST 5x50
				30
				X6

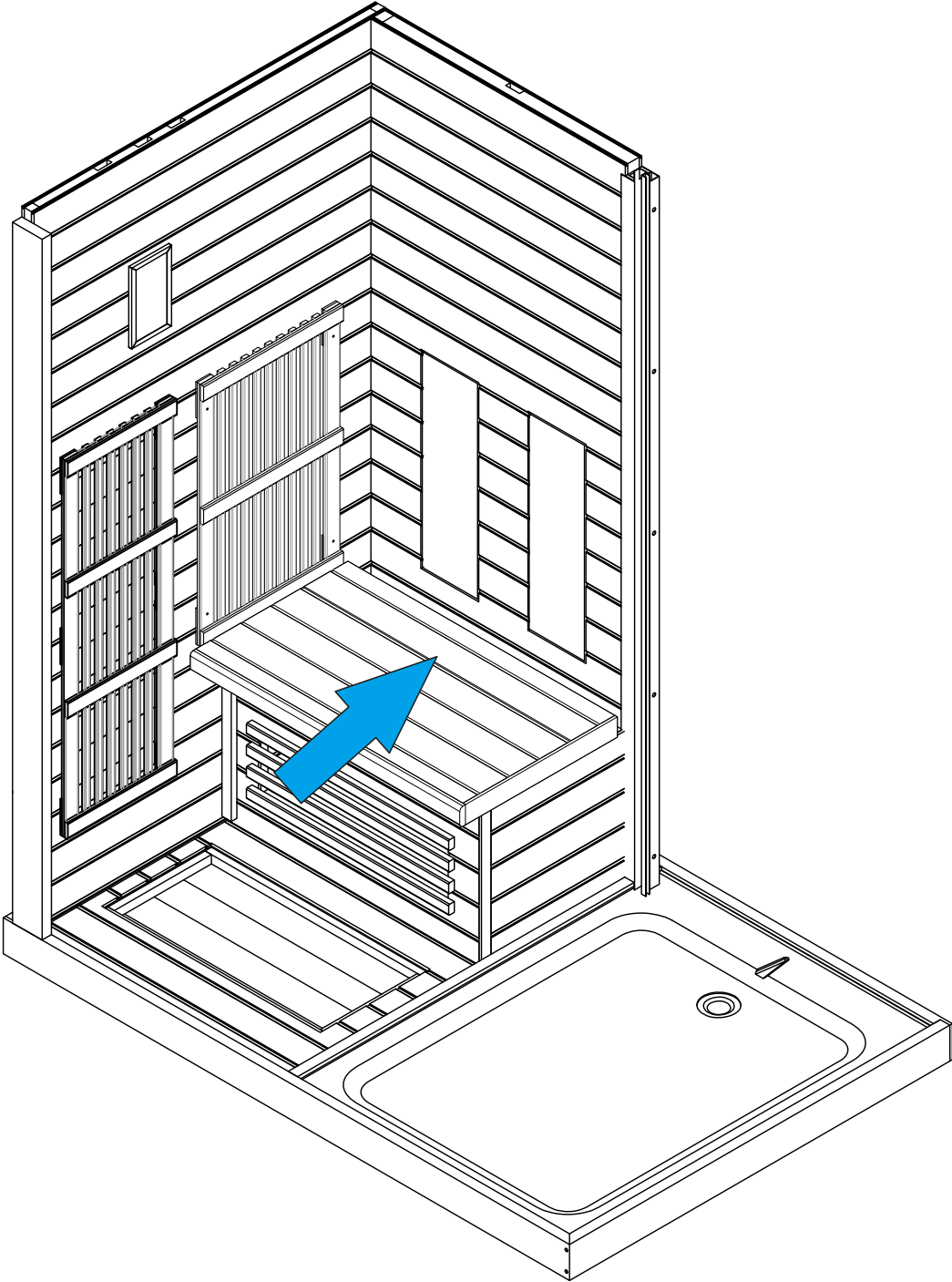
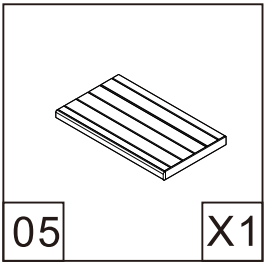

Etape:03

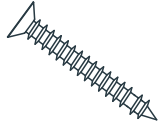

Etape:04

 ST 5x60	
20	X2 06
	X1

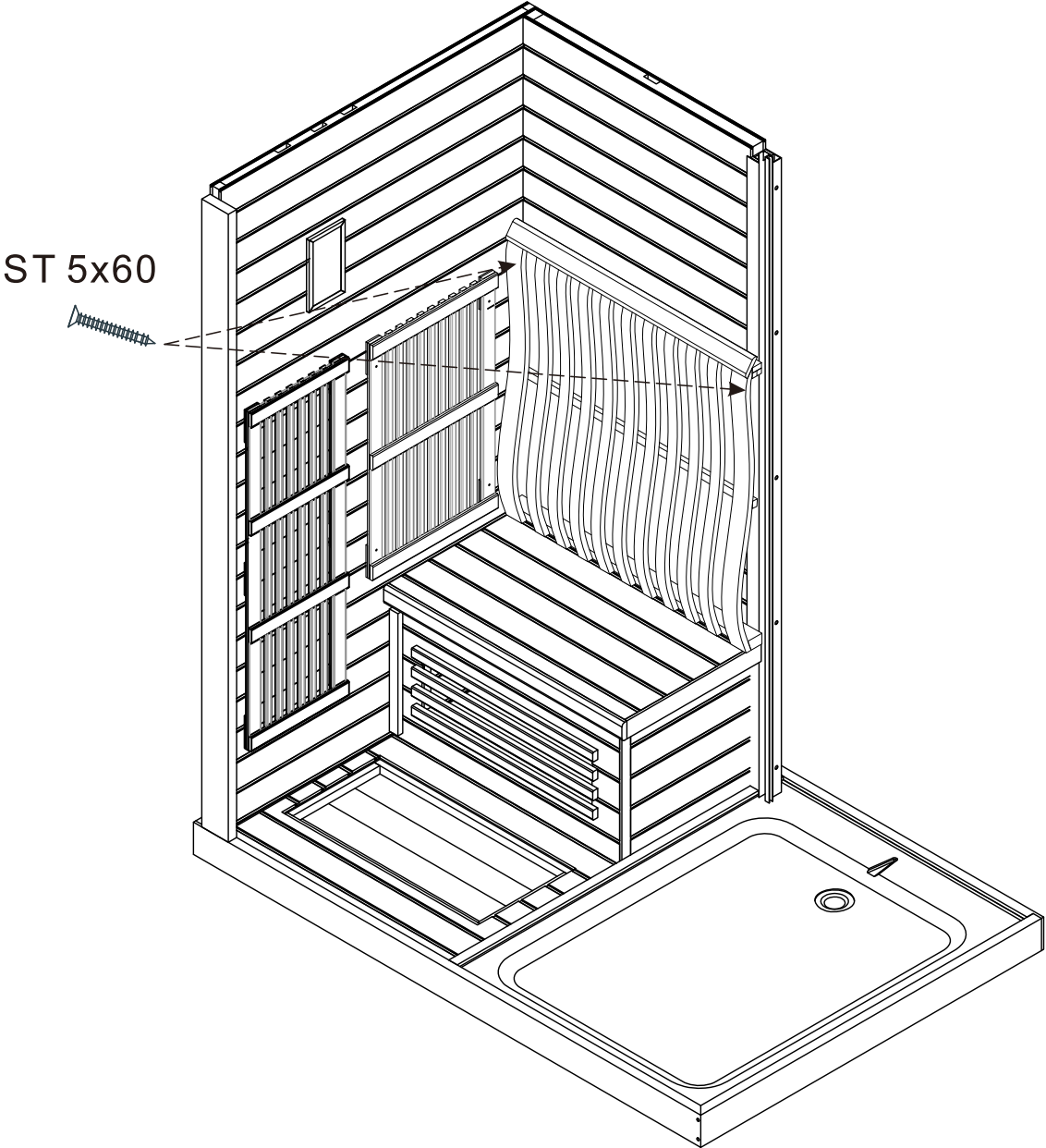

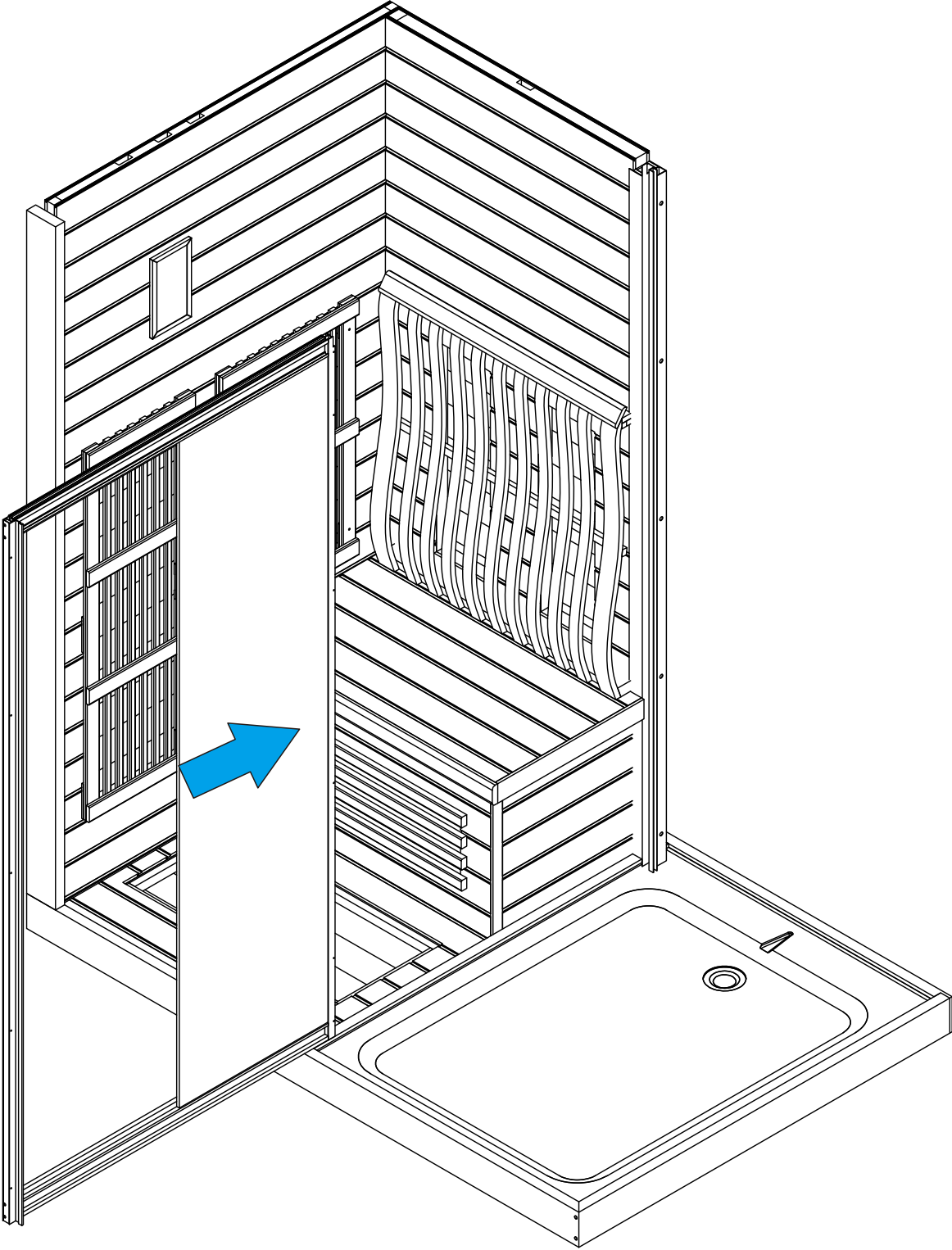
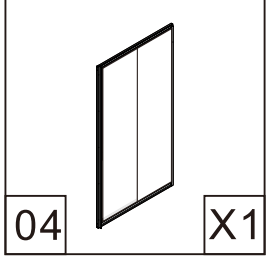

Etape:05

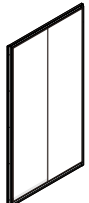

P6

Etape:06

		small head screw
		
		ST 4x12
04	X131	X3

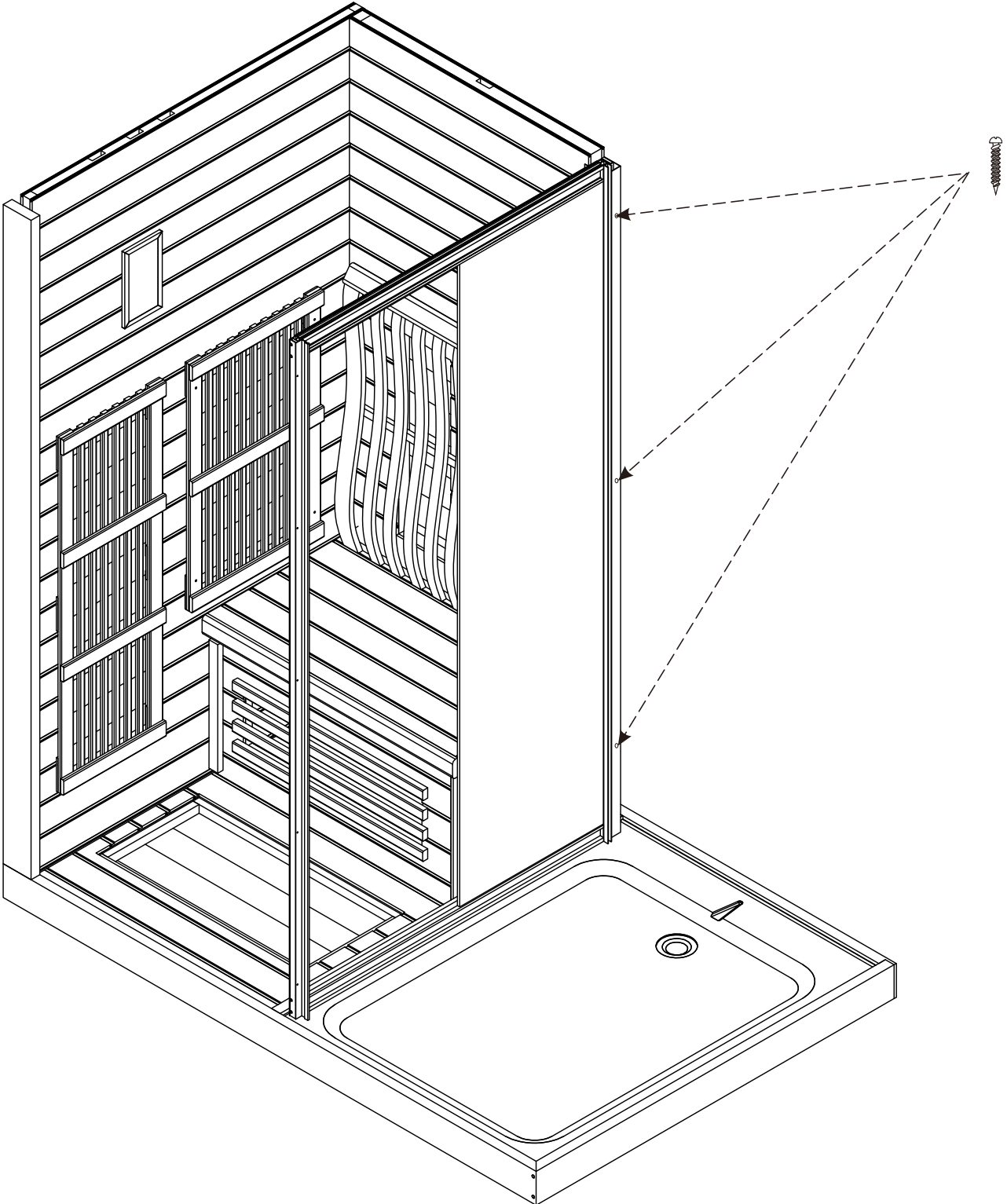



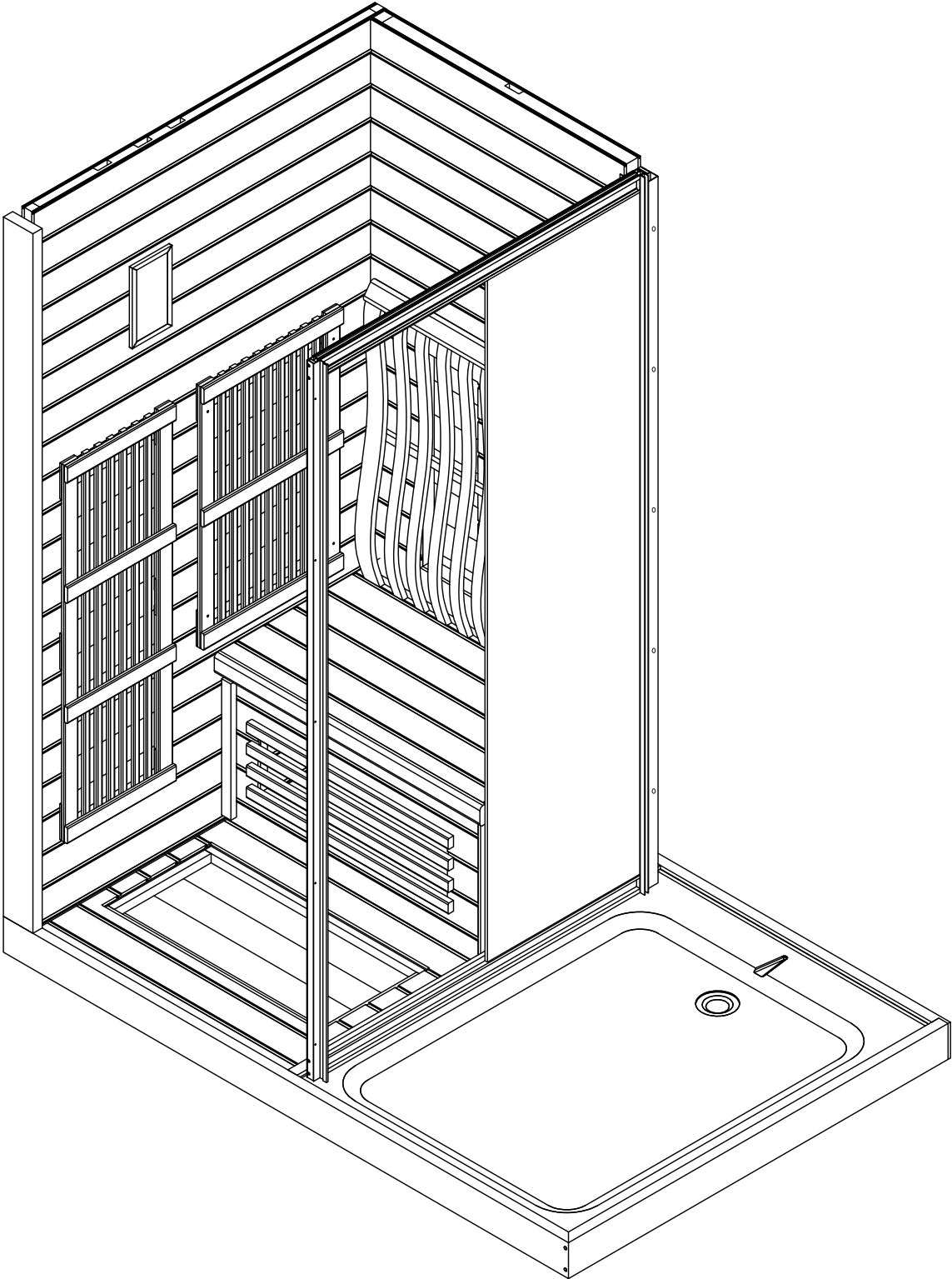
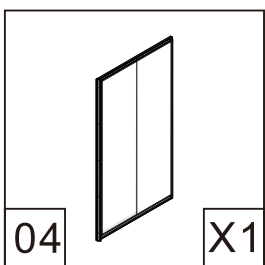

Etape:07

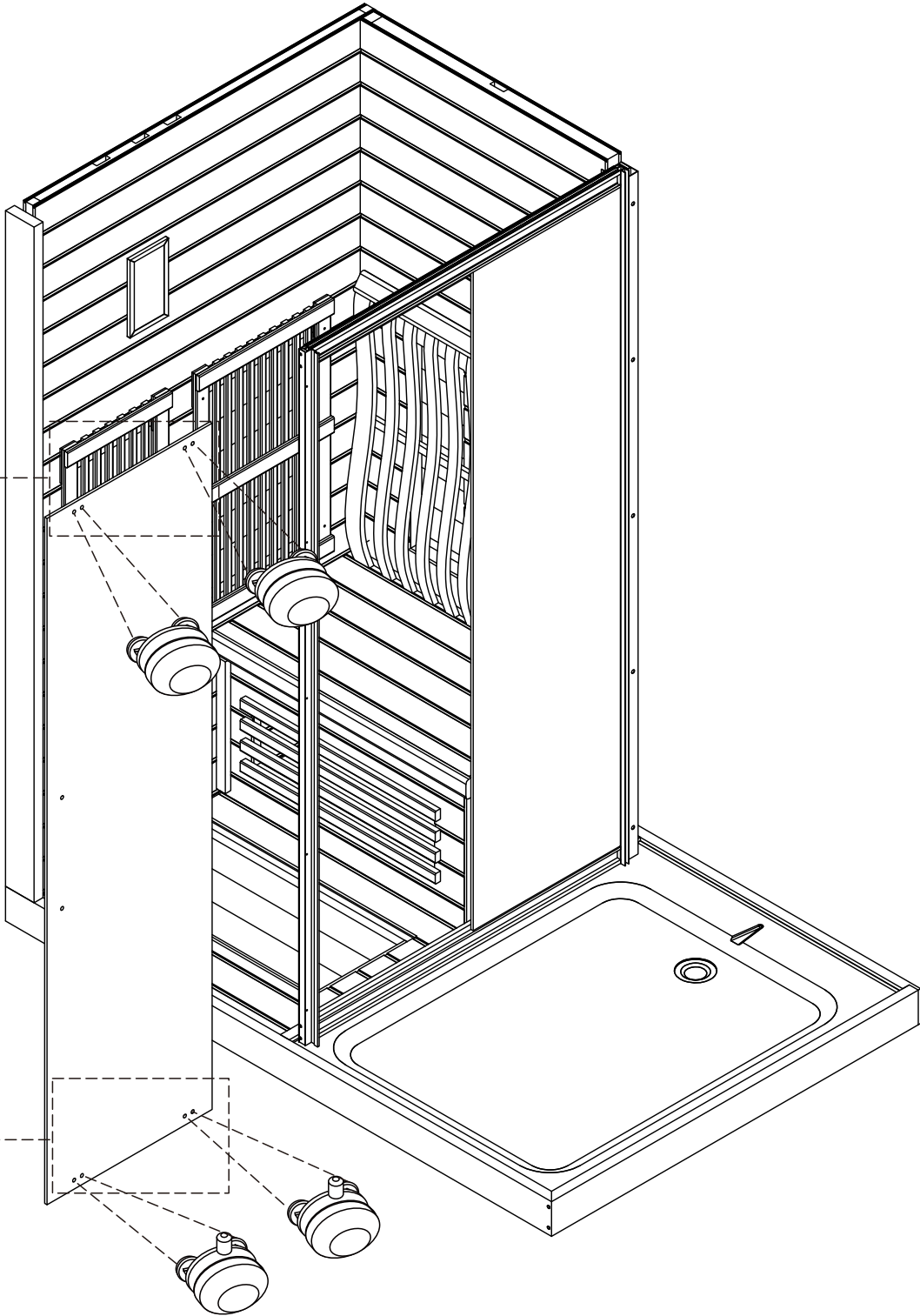
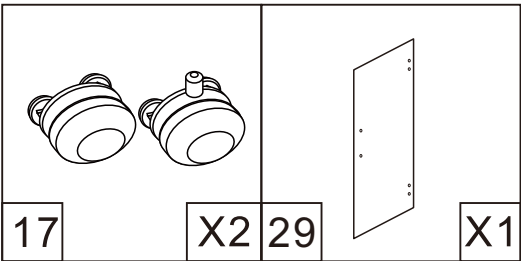

Etape:08

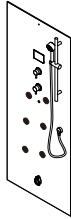

Etape:09

	 big head screw ST 4x12	 M4x25	 M4	
08	X1 32	X3 33	X2 34	X2

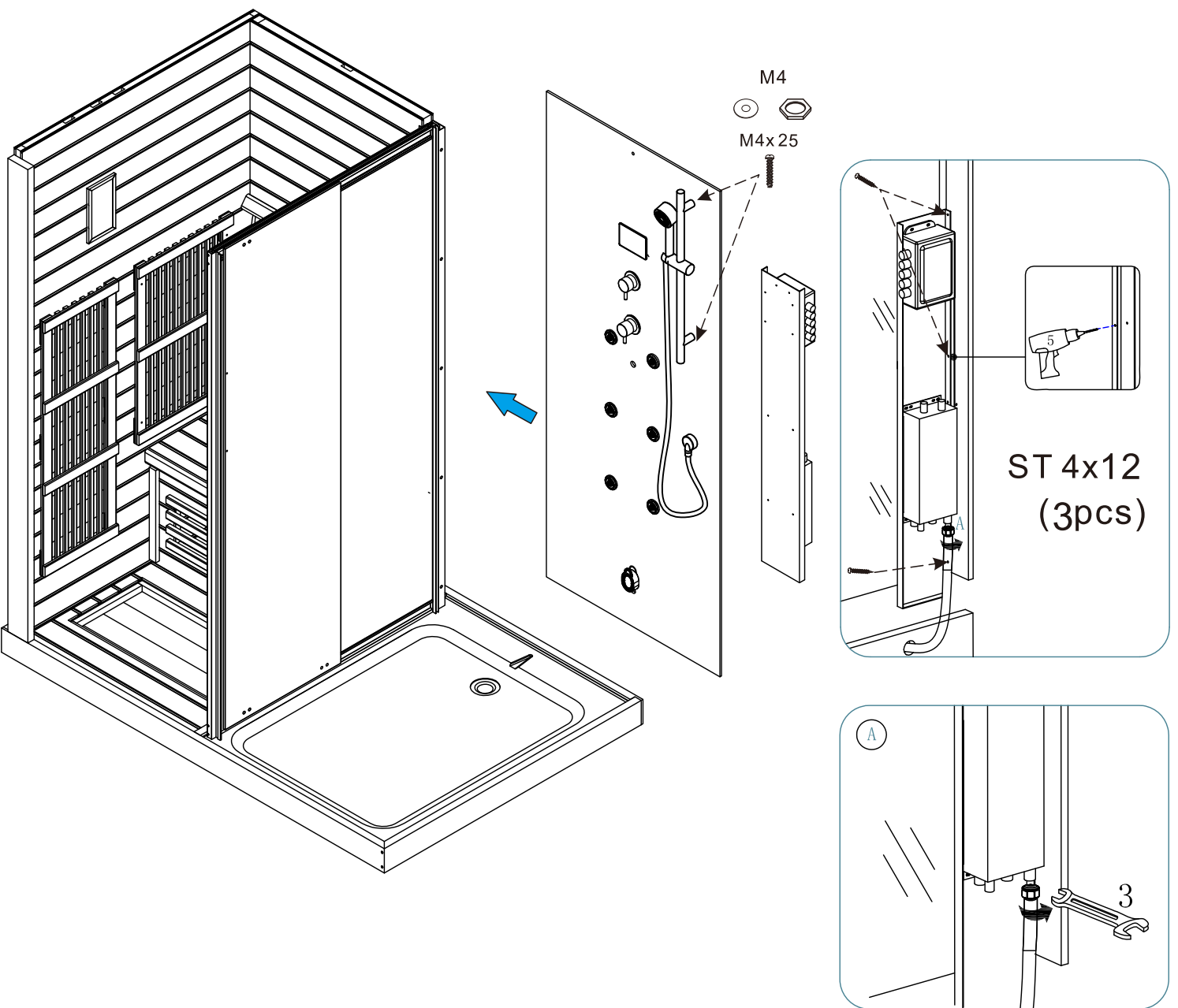

Etape:10

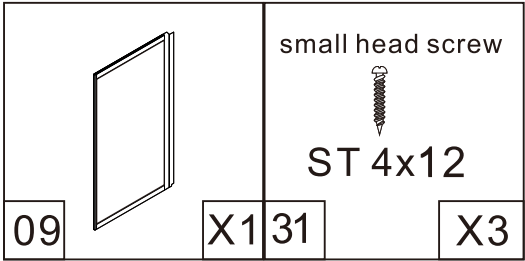

SEAL(LR0201-2.3)

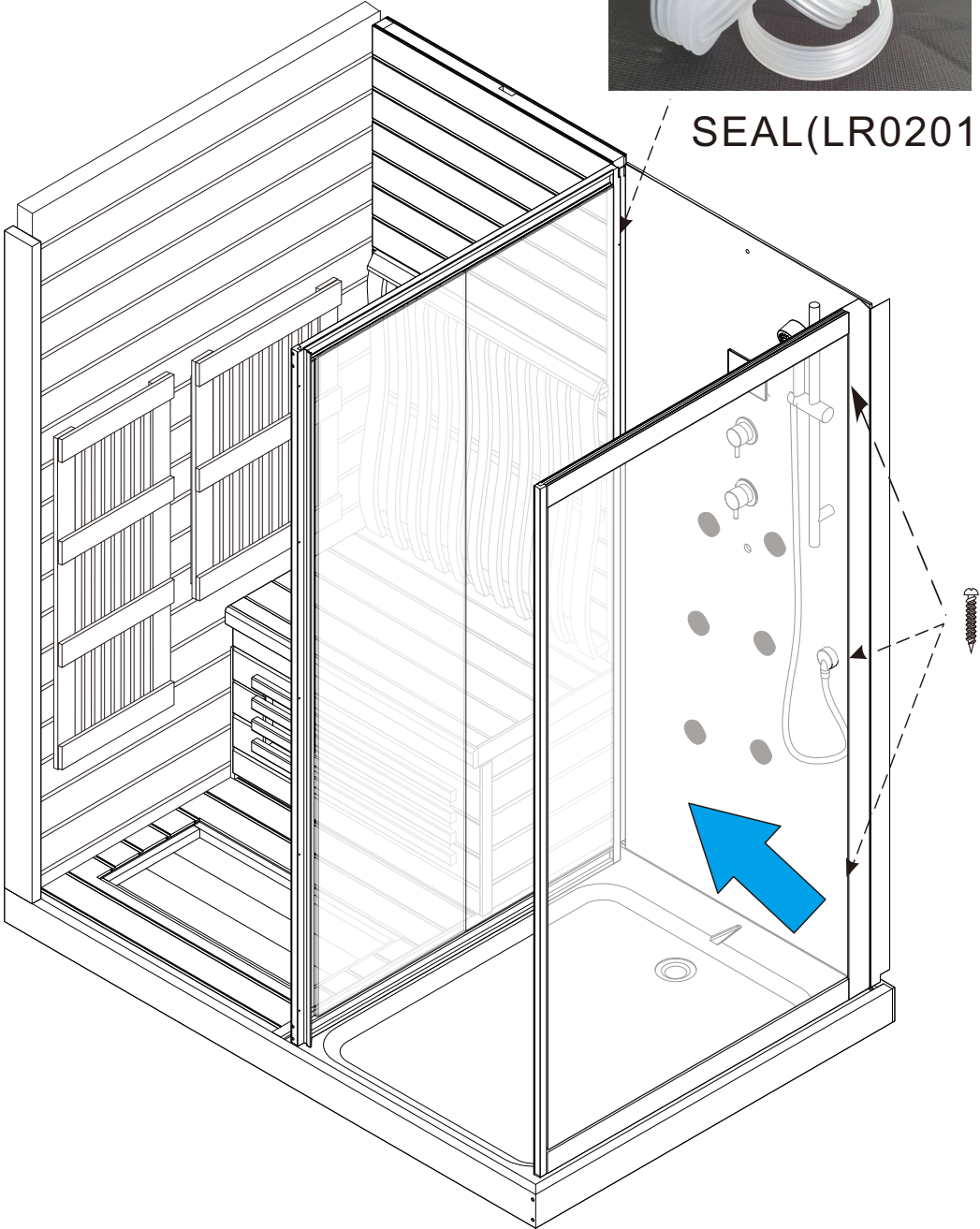

Etape:11

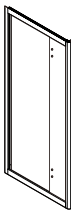
small head screw 			
ST 4x12			
31	X6	12	X1

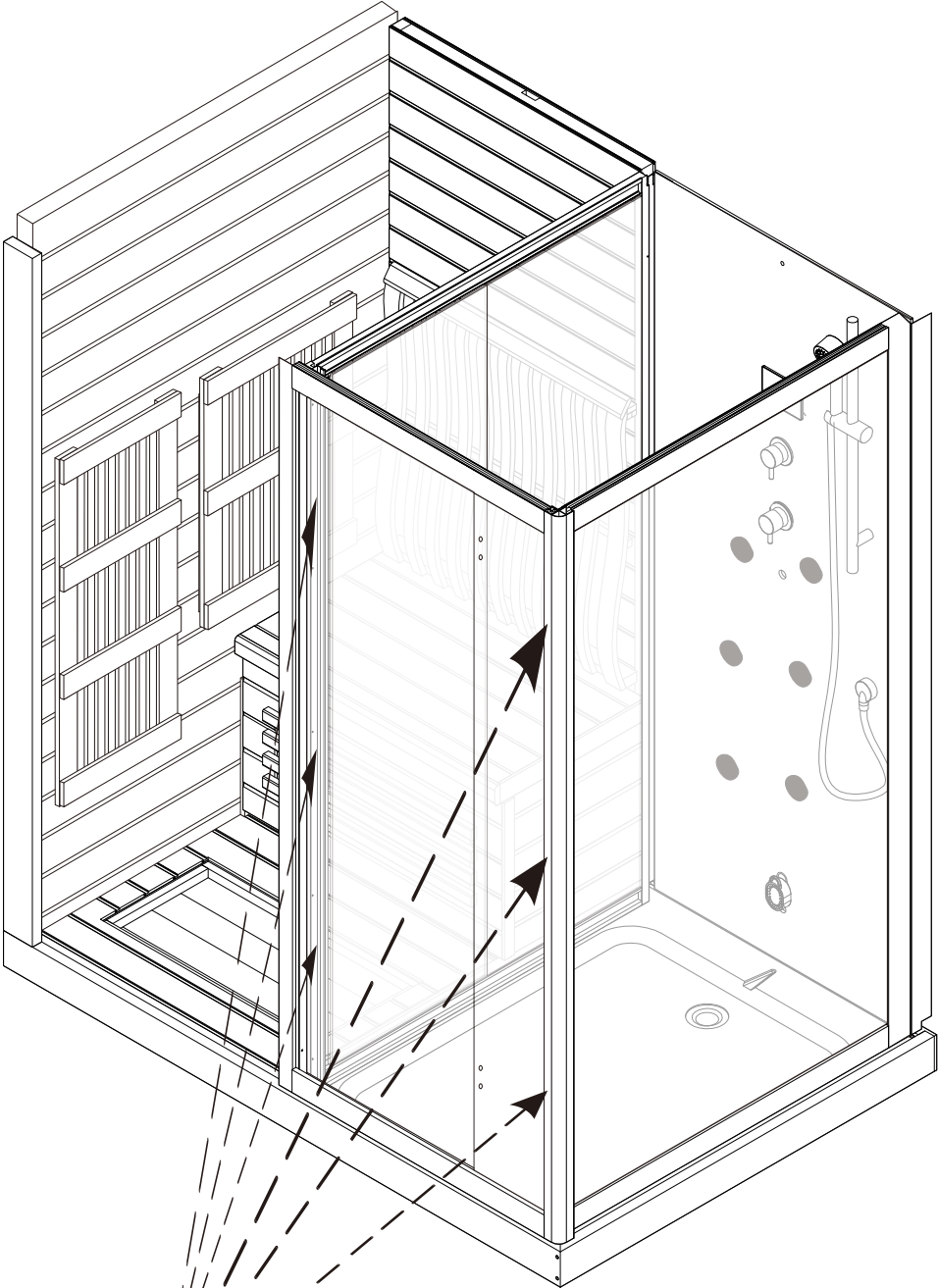





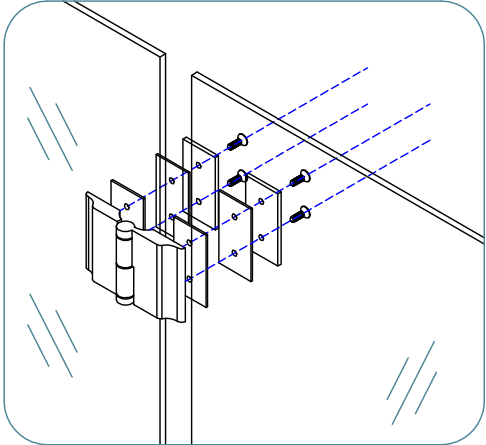
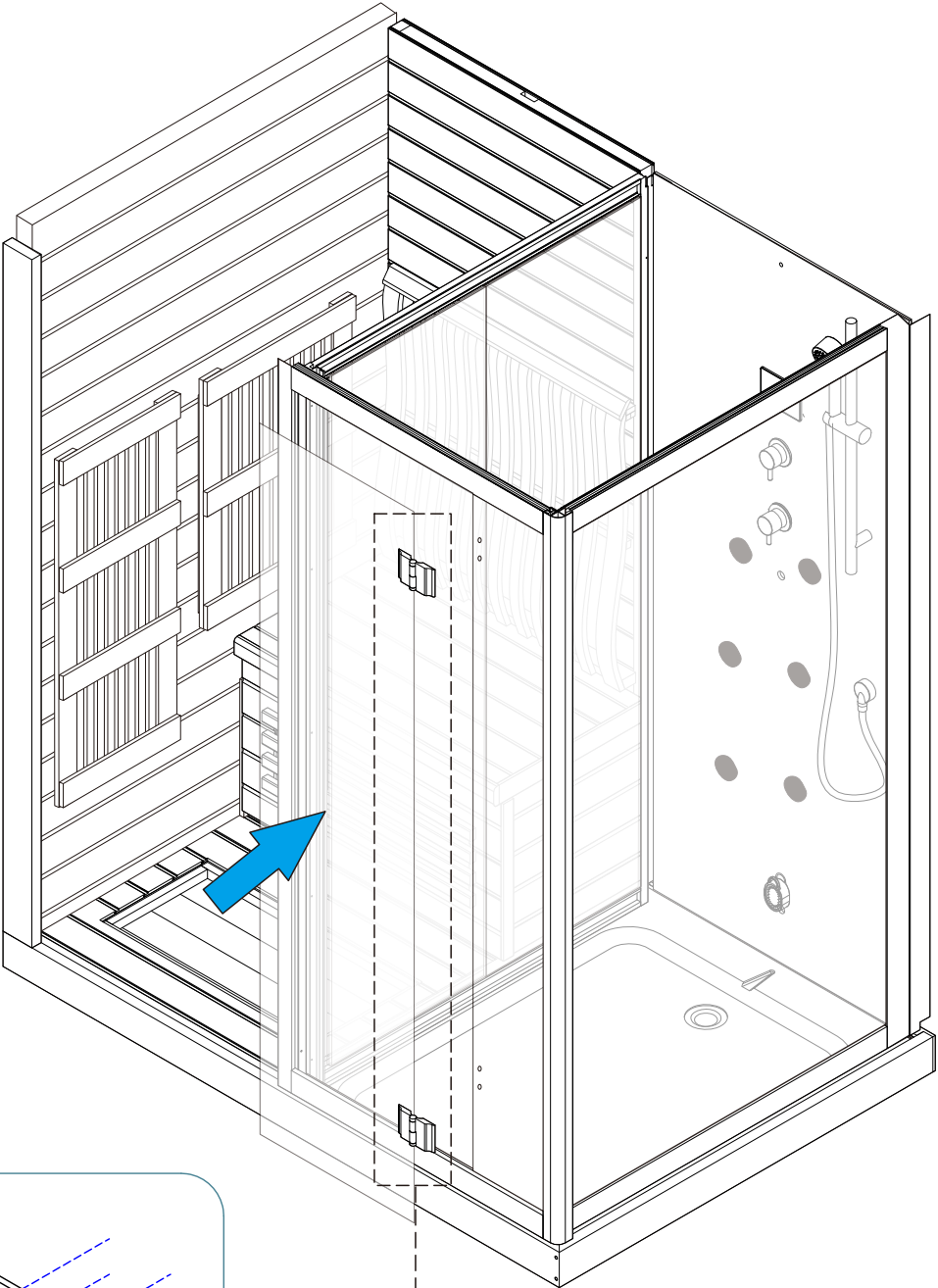
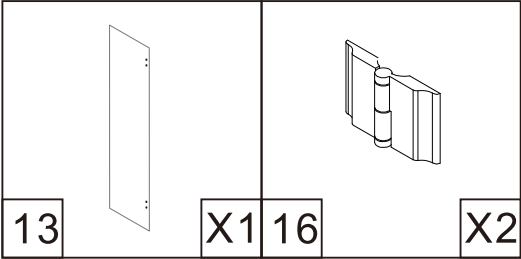

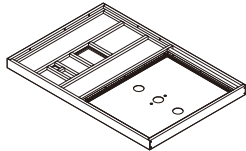

 ST 4x12

Etape:12

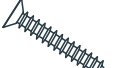

Etape:13

			 big head screw ST 4x12
01	X1 10	X1 32	X4
 ST 4x25			
21	X7 25	X7 26	X7

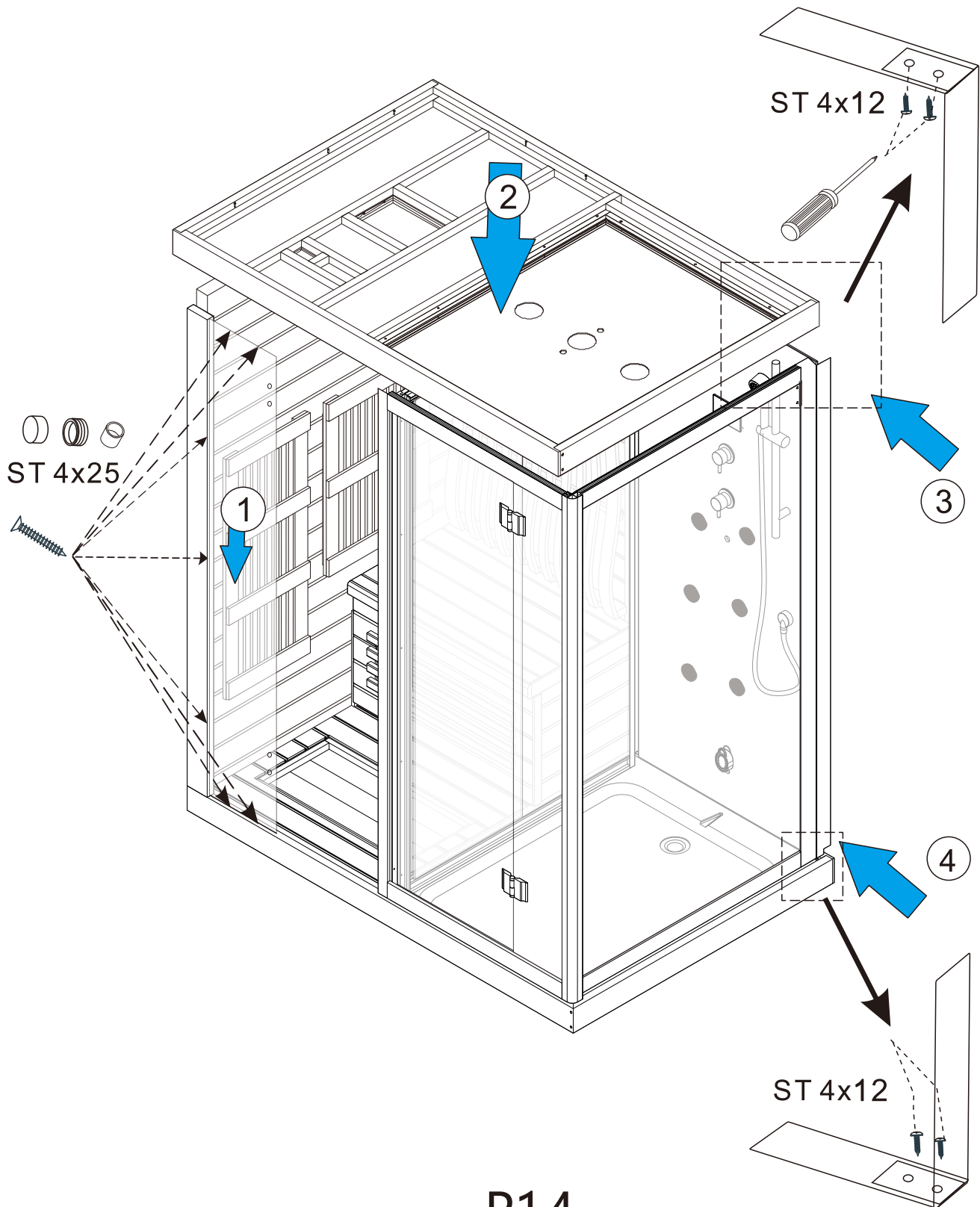

Etape:14

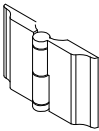
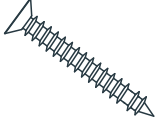
			
11	X1 16	X2 20	X6

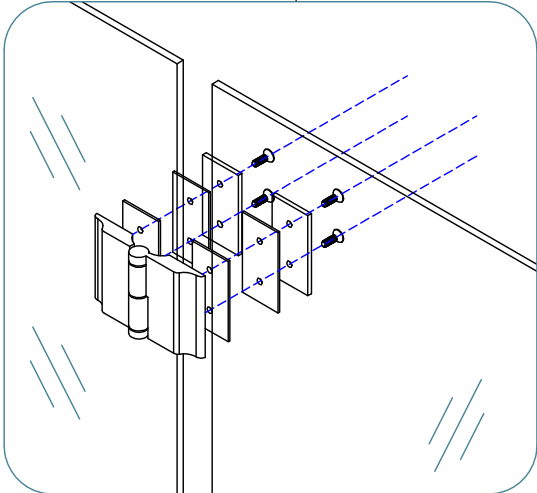
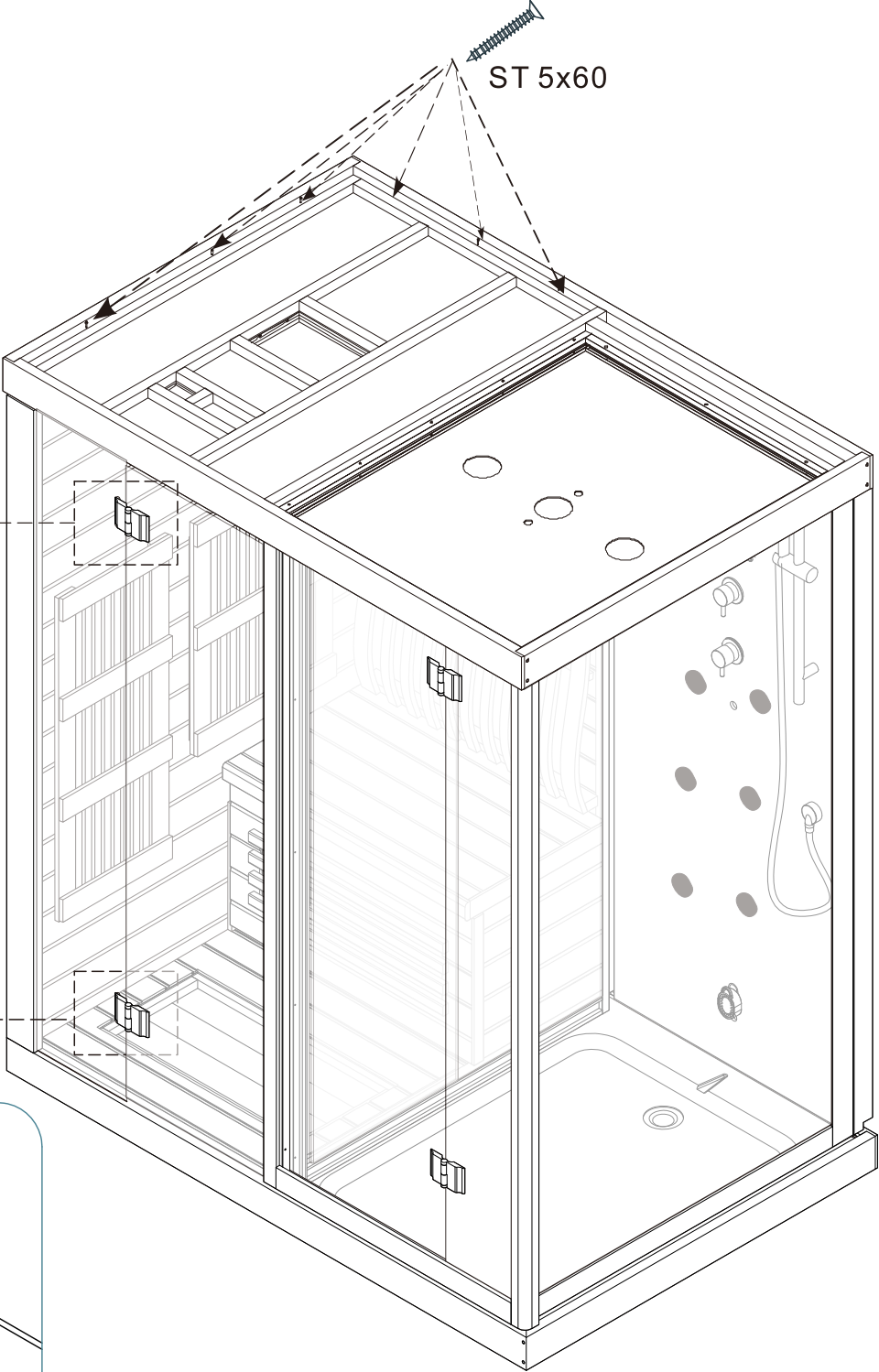

Etape:15

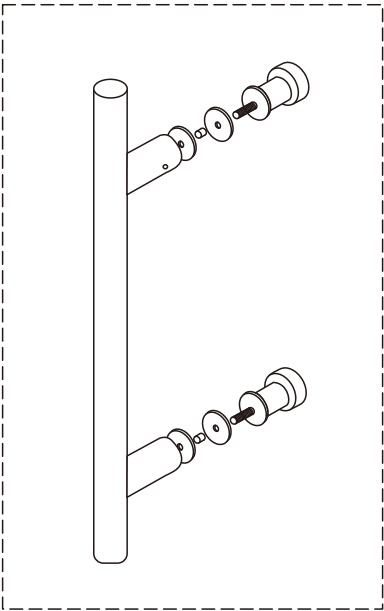
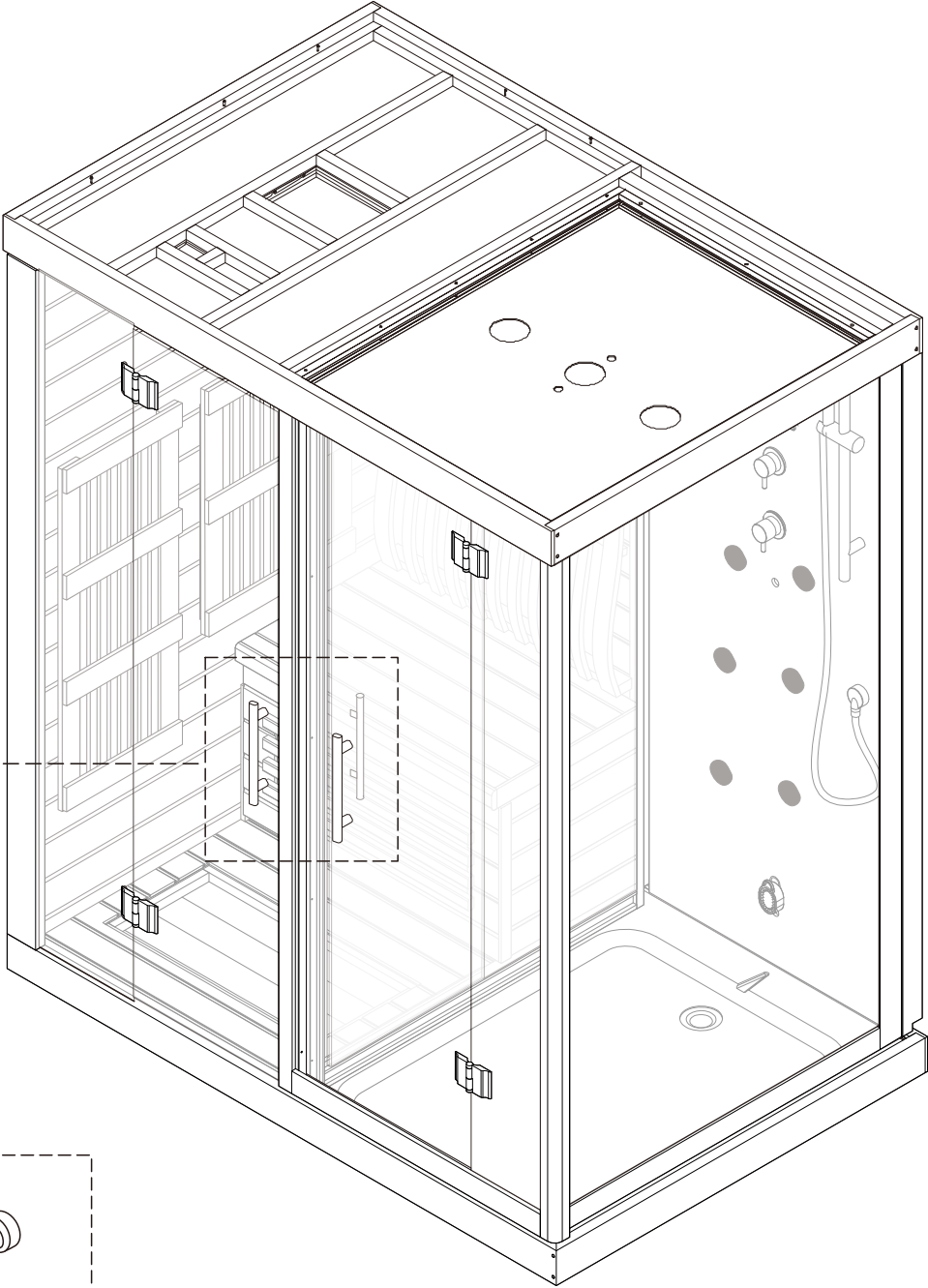
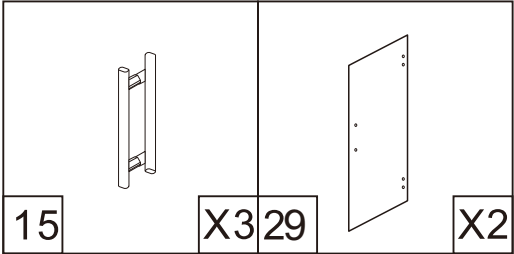

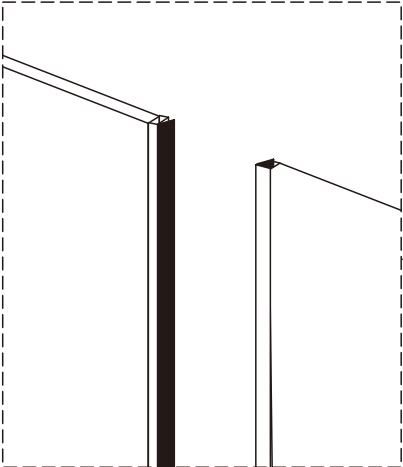
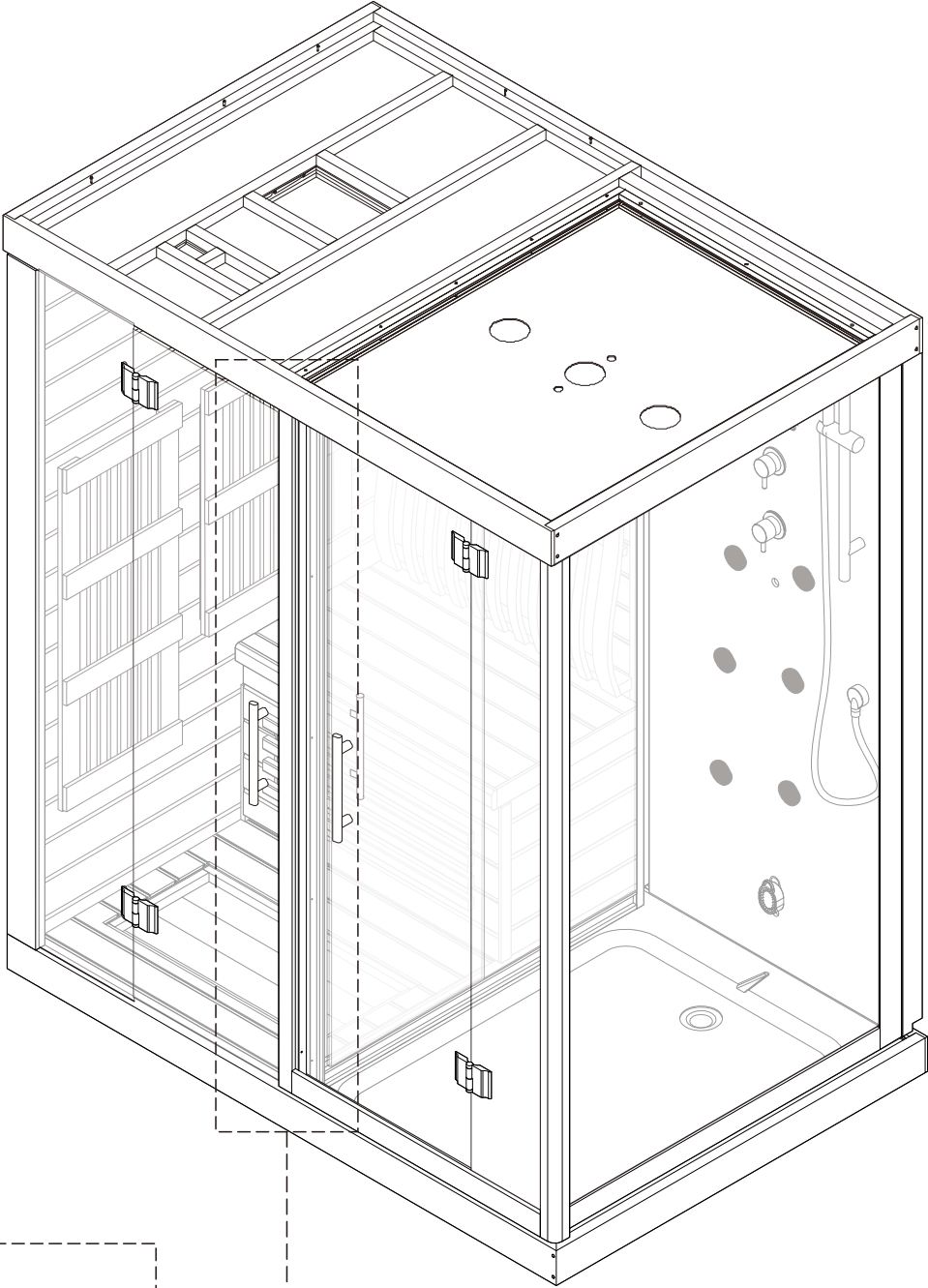

P16

Etape:16

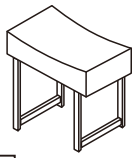

P17

	 M6*20mm		
23	X1	24	X8

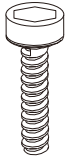

M6*20mm

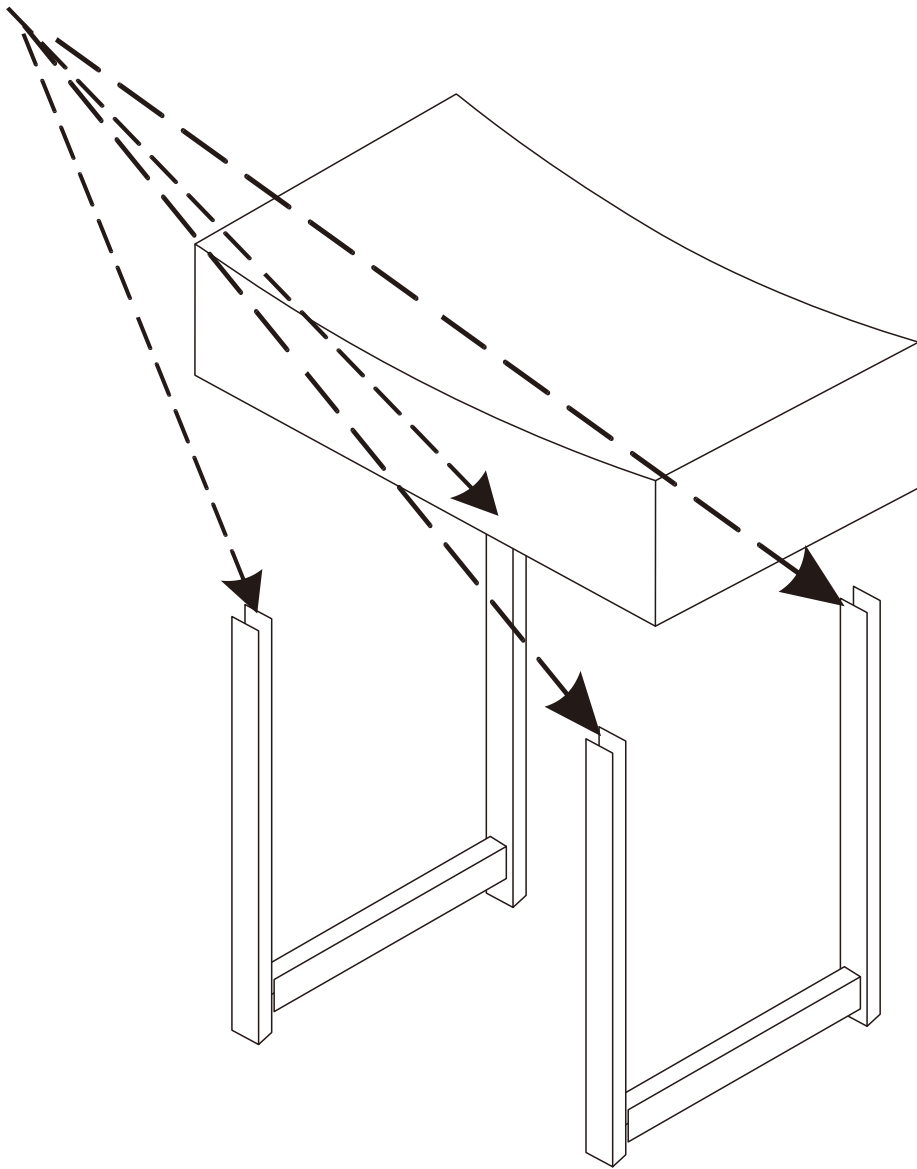

Waterway drawing



Schéma des raccordement hydrauliques et électriques



EN FIN DE MONTAGE :

Raccordement des connexions électriques

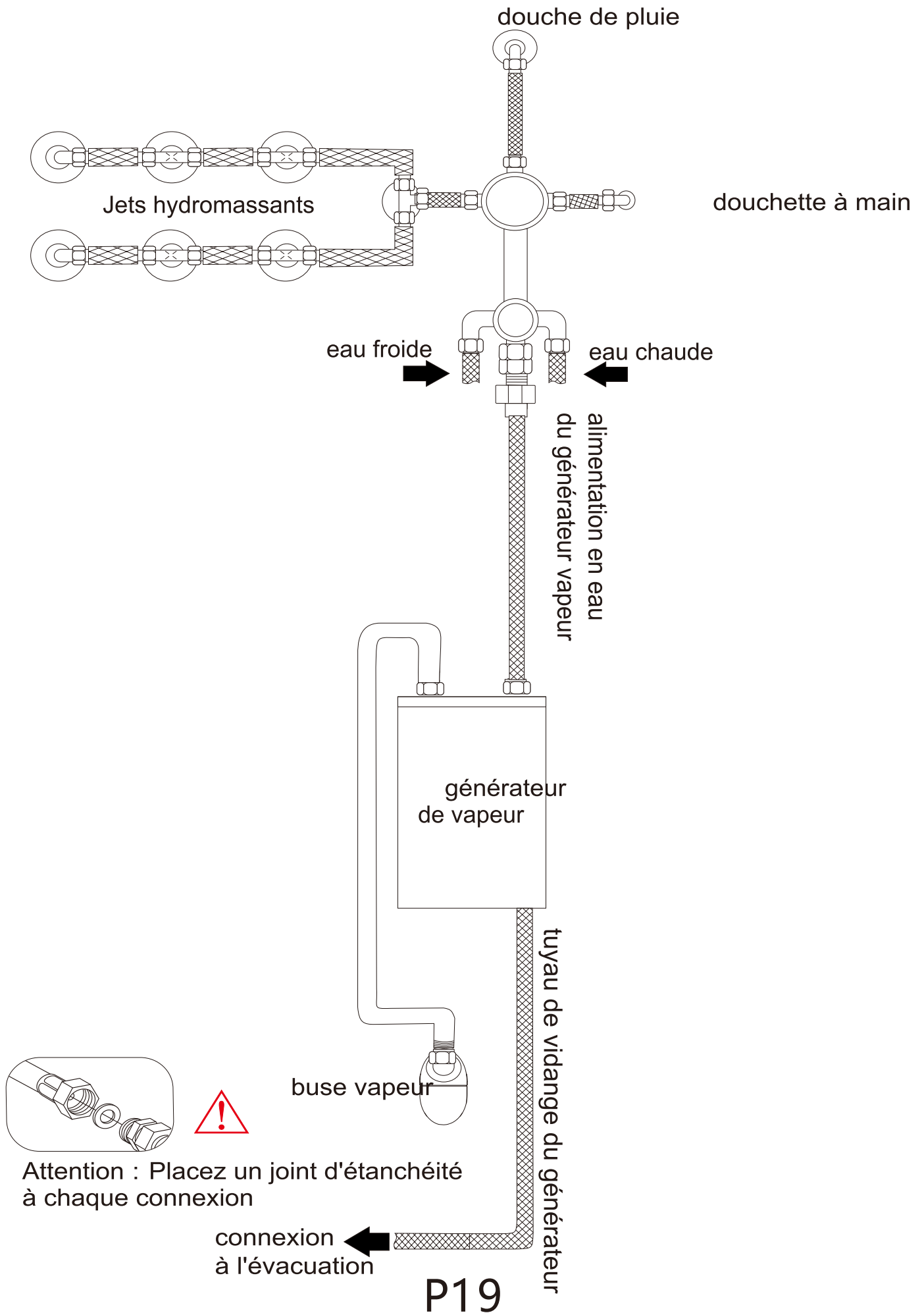
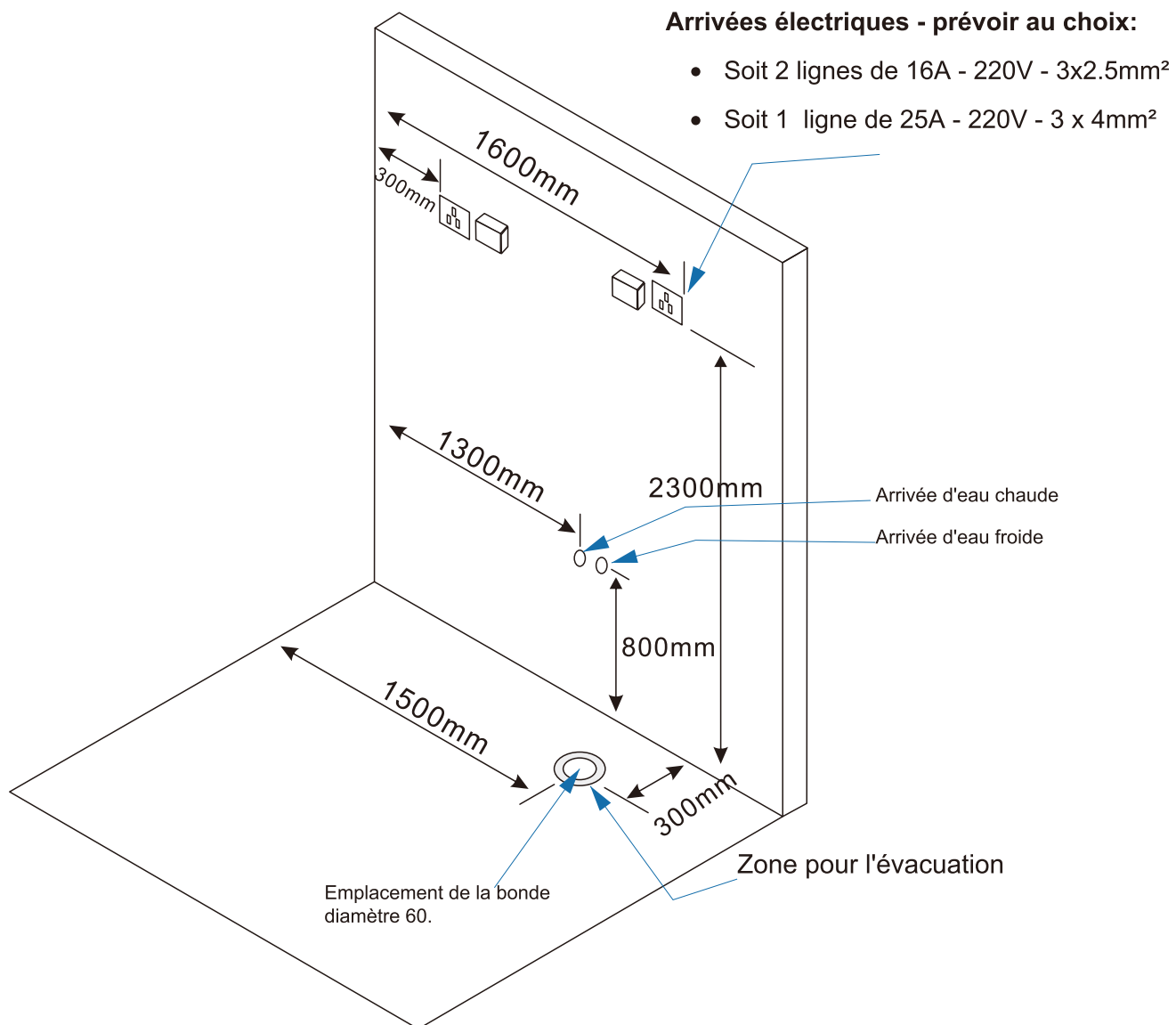
SAUNA

Depuis le toit du sauna, procédez aux raccordements des fiches mâles infrarouges ainsi que des connexions du haut parleur, des LED, de l'ozonateur (O3 - optionnel), et du panneau de contrôle.

DOUCHE HAMMAM

Depuis le toit et l'arrière de la cabine hammam procédez aux raccordements du haut parleur, de la lumière de l'ozonateur (O3 - optionnel), et du panneau de contrôle.

Étanchéité

En partie douche hammam, faites procéder par un plombier professionnel à la vérification des arrivées d'eau et de l'évacuation, et ajouter un joint de silicone en périphérie du receveur ainsi qu'entre les différents panneaux.

